

EXPLODED VIEW & PARTS LISTING

Air Operated Double Diaphragm Pump

Model: DP-40BPT-HD (XDP)

Part#: 854399



To Purchase:

☎ 800-990-7867

✉ sales@yamadapump.com

📍 Find My Rep

More Information:

▶ YouTube: @yamadapump

🌐 yamadapump.com

Data Sheets | CAD Drawings | Manuals
Literature | BOM | Performance Curves

Trial Program

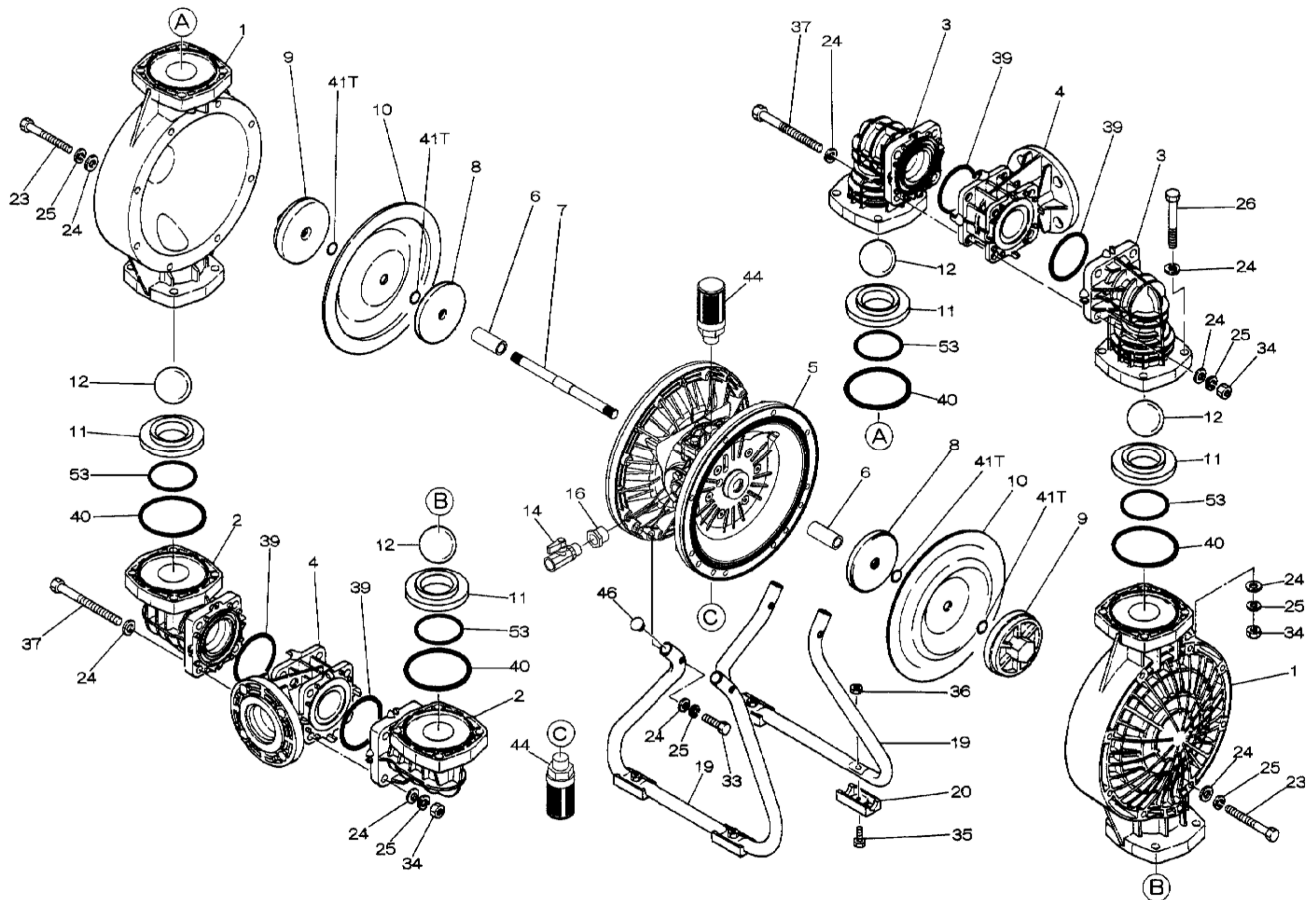

Air Operated Double Diaphragm Pump

804850 Center Body Assembly

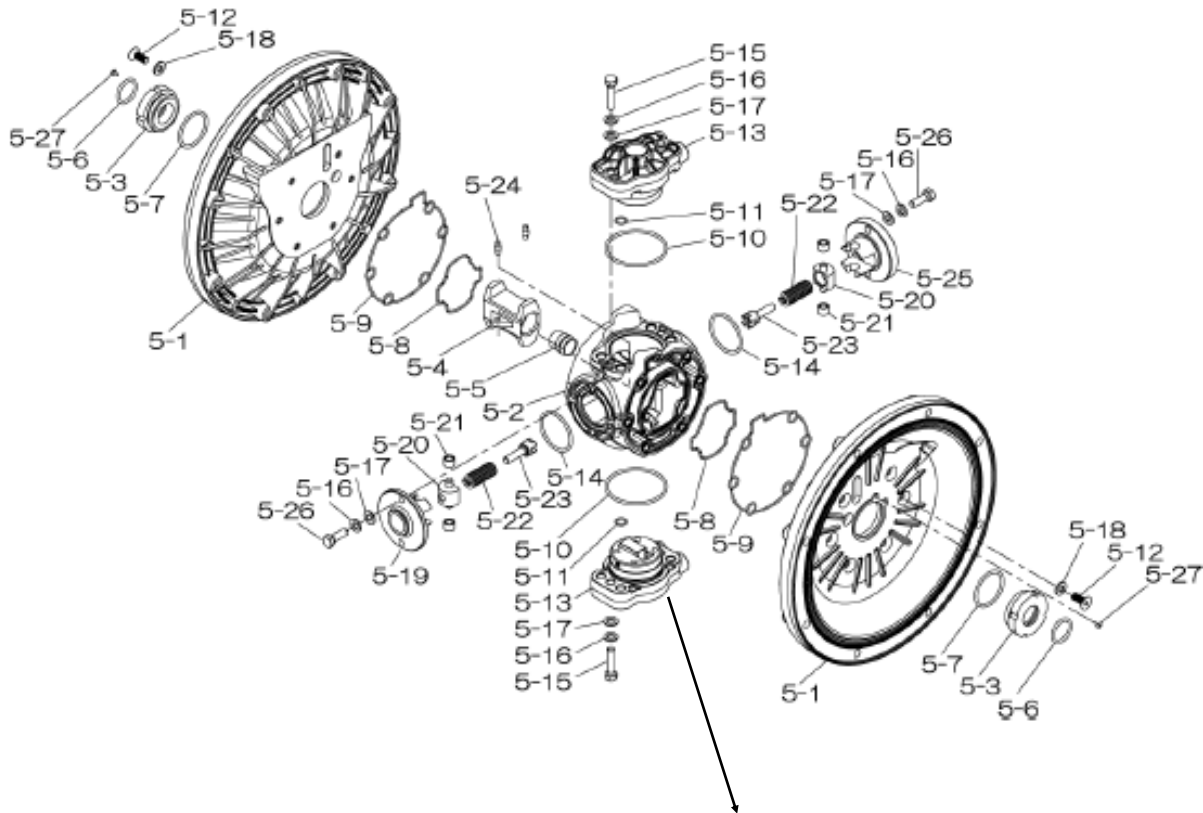

804784 Valve Body Assembly

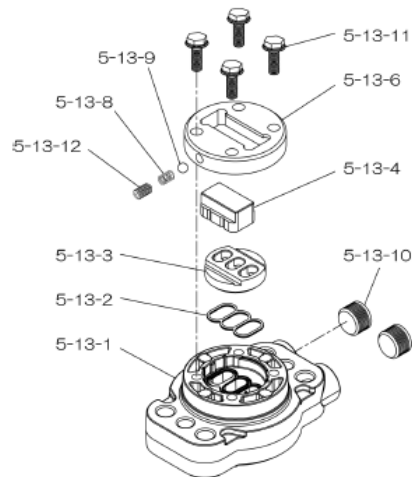

Air Operated Double Diaphragm Pump

REF. No.	PARTS No.	DESCRIPTION	QTY.	REORDER
1	780147	OUT CHAMBER	2	
2	780244	IN MANIFOLD	2	
3	780150	OUT MANIFOLD	2	
4	780248	CENTER MANIFOLD	2	
5	804850	CENTER BODY ASSY	1	
5- 1	716215	AIR CHAMBER	2	
5- 2	716256	BODY	1	
5- 3	773095	THROAT BEARING	2	
5- 4	716214	SHUTTLE	1	
5- 5	773047	CENTER ROD GUIDE	1	
5- 6	640023	O-RING	2	
5- 7	640133	O-RING	2	
5- 8	773040	GASKET	2	
5- 9	773041	GASKET	2	
5-10	640138	O-RING	2	
5-11	640007	O-RING	8	
5-12	683812	FLAT SOCKET	12	
5-13	804784	VALVE BODY ASSY	2	
5-13- 1	716244	VALVE BODY	1	
5-13- 2	773042	GASKET	2	
5-13- 3	716246	SEAT	1	
5-13- 4	773425	BLOCK	1	
5-13- 6	773426	GUIDE PLATE	1	
5-13- 8	706612	SPRING INK	1	
5-13- 9	686271	BALL	1	
5-13-10	772934	PLUG	2	
5-13-11	602300	TAPPING BOLT	4	
5-13-12	610025	HEX. SOCKET HEAD SCREW	1	
5-14	640134	O-RING	2	
5-15	611153	BOLT HEX FT	4	
5-16	631420	SPRING WASHER	8	
5-17	631013	FLAT WASHER	8	
5-18	684987	WASHER	12	
5-19	716249	RETAINER	1	
5-20	713620	SPRING GUIDE	2	
5-21	773067	BUSH	4	
5-22	684537	SPRING	2	
5-23	714446	TRIP ARM	2	
5-24	700231	PIN	2	
5-25	716216	RETAINER	1	
5-26	611149	BOLT	4	
5-27	686337	TAPPING SCREW	2	

REF. No.	PARTS No.	DESCRIPTION	QTY.	REORDER
6	716399	CENTER BUSH	2	
7	716404	CENTER ROD	1	
8	707817	CENTER DISK 40T INNER	2	
9	771726	CENTER DISK 40PP-T	2	
10	770814	DIAPHRAGM	2	
11	772096	VALVE SEAT	4	
12	770692	BALL	4	
14	684321	BALL VALVE	1	
16	684339	BUSHING	1	
19	711925	STAND 40PP	2	
20	771865	FOOT RUBBER	4	
23	686156	BOLT HEX	16	
24	631330	FLAT WASHER	68	
25	680257	SPRING WASHER	44	
26	621183	BOLT HEX	16	
33	621179	BOLT HEX	4	
34	628013	NUT	24	
35	621149	BOLT	4	
36	683837	NUT W/ FLANGE	4	
37	683542	BOLT	8	
39	643060	O-RING	4	
40	643064	O-RING	4	
41T	643015	O-RING	4	
44	804697	MUFFLER	2	
46	683641	CAP STAND	4	
53	643136	O-RING	4	
KIT	K40-PT	LIQUID SIDE KIT		
KIT	K45-AM-DP-HD	AIR MOTOR KIT		

General Tools:

- Socket wrench - 24mm
- Hexagonal box wrench - 5mm, 6mm
- Open-end wrenches - 19mm, 24mm
- Phillips head screw driver

Special Tools:

- Socket (804129) for a guide to remove the throat bearing (sold separately)

Miscellaneous:

- Assembly Oil - Turbine oil class 1 (equivalent to ISO VG32 grade)
- Nuts - M16 x 1.5
- Thread locker
- Urea grease grade (NLGI) No. 2, Shell Alvania Grease S1

Torque Requirements:

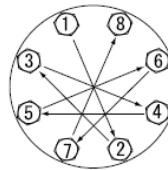

Tightening torque for center rod and out chambers.
Center Rod 36 ft-lbf {50 N-m}
Out Chambers 26 ft-lbf {35 N-m}

Tightening torque for manifold retainer bolts.
BPT-HD 15 ft-lbf {20 N-m}

Customer Notes

Model #: _____
Description: _____
Serial #: _____
Date Installed: _____
Department Location: _____
Tag/Project: _____